

## **Model BVAC-1600-CC**

12" DIA. X 18" Work Area  
TURBO-PUMPED HIGH VACUUM FURNACE  
For programmed continuous operation to 1600° C.



Size: 65" (165 cm) W. x 28" (72 cm) D. x 50" (27 cm)H.

*A High Vacuum and Atmosphere version of the CAMCo Model B Furnace.  
B-VAC Furnaces are available with ratings to 2300° C .*

### **Standard Features**

- 550 LPM Turbo Pump
- High Vacuum isolation valve
- 50 Programs – 15 Segments per program
- Fully Automatic
- Vacuum Delay Setpoint
- All Stainless Steel construction

### **Options**

- Cable Hoist
- Paperless Chart Recorder
- Tower Indicating Lights – 3 color
- Survey Thermocouples
- Combination Hydrogen atmosphere



Manufacturers of High Temperature & High Vacuum Equipment

370-G Industrial Road | San Carlos, CA 94070  
 Phone (650) 593-1064 | Fax (650) 593-4458



## Specification Sheet

Equipment Model: BVAC-1600-CC  
 High Vacuum Furnace

<b>Type</b>	Coldwall, Vertical, Top Loading/High Vacuum
<b>Maximum Temperature</b>	1600 Degrees C.
<b>Hot Zone</b>	12" (30 cm) Dia. x 18" (45 cm) H. Nominal
<b>Frame Dimensions</b>	72" (183 cm) W. x 28" (72 cm) D. x 50" (127 cm) H.
<b>Power Requirements</b>	480V 3 Ph. 60A 60 Hz. – 240V 3 Ph. 120A 60 Hz.
	415V 3 Ph. 60A 50 Hz.
<b>Gas Requirements</b>	25 – 50 psig, Nitrogen (1/4" swagelok)
<b>Compressed Air</b>	80 – 100 psi (1/4" swagelok)
<b>Element style</b>	.125 Molybdenum wire

Process Vacuum at temperature  $10^{-6}$  Torr range  
 Vacuum in  $10^{-7}$  Torr range at ambient

**Cooling Requirements** - 25 psig at 4 gallons per min. Note maximum back pressure is 15 psig.

Heat up ramp rate 100 degrees C per minute - empty chamber.

Heating elements and heat shields are constructed of Molybdenum.

### Standard Features:

- 600 LPM Turbo Pump
- High Vacuum Isolation valve
- Equipment on casters to roll into place
- PC based controls
- Entivity Studio control software
- 50 Programs - 15 segments per program
- Sight glass for calibration melts
- Fully automatic - One button push starts the run. Automatically it will rough pump/cross over to high vac - ramp to temperature and soak - cooldown - let up to ATM - and show amber indicator light when run is finished.

### Options:

- Active Braze Control
- Cable Hoist
- Paperless Chart Recorder
- Survey Thermocouple
- Tower Indicating Lights - 3 color



Manufacturers of High Temperature & High Vacuum Equipment

370-G Industrial Road | San Carlos, CA 94070  
Phone (650) 593-1064 | Fax (650) 593-4458

## Equipment Description

### CAMCo 12" Dia. X 18" H. , 1600 deg. C Computer Controlled

TURBO-PUMPED, HIGH VACUUM FURNACE  
*For Automatic, Programmed Operation to 1600 deg. C*

### Model BVAC-1600-CC



## **Overview**

The Concepts & Methods Co., Inc. B-Vac 1600 high vacuum furnace is designed to reproducibly vacuum braze, degas and otherwise process loads of up to 11 inches wide by 17 inches deep. The number selected ramp and soak program is accurately controlled to 1,600 deg. C. at pressures to the  $10^{-6}$  Torr range. The furnace and vacuum controls, pump system and interlocks are integrated in a fully automated in a computer controlled unit to assure simple, reliable operation.

The furnace chamber, centered in the base unit is of the top-loading "coldwall" variety, capable of continuous operation at 1600 degrees C. It incorporates a low voltage, three phase Molybdenum heating element powered by its' 350 ampere electrodes. These include Teflon and Alumina insulation and Viton seals. The element surrounds the 12 inch diameter by 18 inch high work area. Work is placed on a Molybdenum hearth plate, 12" diameter, which in turn is held by the support structure within the chamber. A stack of six Molybdenum cylindrical heat shields, the bottom end stack of eight Molybdenum shields, and the similar removable top shield stack surround the element.

A double wall, water-jacketed stainless steel chamber contains these items as well as the water cooled, insulated power feedthroughs and control and work thermocouples. A Nickel-plated Copper water-cooled baffle within the chamber isolates the pumping neck from heat radiated by the furnace. A hinged, water-jacketed cover assembly is easily Viton "O" ring sealed to the chamber through use of a camming latch.

A 5/8" inside diameter vertical sightport is located at the center of the cover. In registration with this are holes of approximately 7/16" diameter, which penetrate the top heat shield stack.

A "flag" in close thermal proximity to the work monitoring thermocouple may thus be watched, and a precise calibration thereby verified by melting an elemental metal. The sight glass is sealed through use of a Viton "O" ring, and is readily removable to facilitate cleaning or replacement.

## **Base Unit**

The base unit measures approximately 63" wide by 29" deep (to fit through a standard door) by 50" high. Its' substantial frame is constructed of heavy wall square steel tubing. Service access is readily gained through a hinged steel front door and removable front, side and rear panels.

The plate steel floor within the left third of the base unit supports the heavy transformer and closes the bottom. This left section, containing the power components and electronics is, for safety, isolated from the right two thirds by an internal airflow-directing baffle. A fan at the rear of the base unit draws cooling air through a replaceable filter element to cool the power control unit and transformer.

The floor within the right third of the base unit supports the mechanical pump. In addition, the base frame supports and houses the instrument console, chamber, high vacuum plumbing and cover hinge and latch assemblies.

A convenient feature is the inclusion of recessed heavy-duty casters. The unit is easily rolled into place, and the leveling feet lowered to immobilize and level the equipment. The stainless steel top provides an area for convenient load preparation, and completes closure of the base unit. The finish used on this, and all CAMCo equipment is baked, environmentally friendly powder coating, chosen for its' durability.

## System and Temperature Control

Temperature control and monitoring functions are achieved using standard computer and I/O module, incorporating Entivity Studio-Think and Do control software. The computer operates solenoid valves for control of vacuum and venting valves. All inputs, digital and analog, are monitored thru the I/O module and transferred to the computer and updated 20 times a second. A large screen is supplied along with a standard keyboard and mouse pad, for operator interface. All thermocouple and vacuum readings, along with valve status, is incorporated on an easy to read screen.

Multi-stage programmed control is achieved through use of this computer controlled automated system which receives its' input signal from the thermocouples and remote vacuum gauges. Automatic time/temperature ramp and soak programmed control of up to ten different, 14 segment programs may be stored. The operator is required only to insert the load, specify a program by number and press the start button to operate the furnace.

Load temperature is monitored by the computer and a separate process controller, which provides digital readout of the load area temperature and provides an over temperature shutdown. The computer and overtemp monitor receive their signal via a second thermocouple located within close proximity to the load.

A Thermocouple feedthrough at the side of the chamber and related holes in the cylindrical shields allow survey thermocouples to be inserted to monitor actual temperature of load. The furnace comes standard with one type "K" Inconel sheathed survey thermocouple that can be attached to the workload. This thermocouple is rated for use up to 1200° C.

## Operation

Work is loaded into the furnace, the top heat shield stack inserted, the cover closed and latched. One of 10 selectable, user programmed thermal profiles is chosen, and the "RUN" button is pushed. The high vacuum isolation valve opens and the chamber is rough pumped through the idle 160 mm, 600 L/PS turbo molecular pump. At a pre-defined vacuum setpoint (approx.  $5.0^{-1}$  Torr) the turbo pump on is automatically turned on and the system is further pumped down to the  $10^{-7}$  Torr pressure range within approximately 15 minutes. The furnace then performs the pre-programmed ramp & soak temperature profile, cool down, and vents to nitrogen. Upon completion of the cooldown portion of the program, the chamber is opened and unloaded.

## Vacuum System

This automatically controlled, turbo pumped version of the type B furnace is designed for clean, oil-free elevated temperature in a high vacuum atmosphere. From a cold start, the clean furnace will evacuate to the  $10^{-7}$  Torr range in approximately 15 minutes, and is capable of maintaining six-scale vacuum at temperature. When pumped for a longer period, lower pressures are easily attained. The vacuum plumbing is designed to provide convenient component access, and to provide maximum practical conductance to the chamber. Mass spectrometer leak checks are performed on all high vacuum assemblies.

The high vacuum system is specifically designed to handle the large gas loads presented by vacuum furnaces. An ISO160 flanged, 600 L/Sec. ceramic bearing turbo molecular pump, capable of  $10^{-9}$  scale ultimate vacuum, is used for the application. The turbo-pump is capable of very rapid 3 thru 7 scale pumping of air and water vapor typically evolved during the earlier outgassing part of the firing cycle. For maximum pumping speed, it is close-coupled to the chamber pumping neck through the high conductance high vacuum gate valve, as are the chamber vacuum gauges and inert gas let-up valve.

Chamber roughing is accomplished through the turbo pump by a quiet, direct drive mechanical pump. The foreline includes a backstreaming trap and electro-pneumatic foreline valve. At acceptable foreline pressure, the turbo-pump is automatically powered up. For ultra clean operations, a dry scroll or diaphragm pump can be substituted for the mechanical pump.

## Vacuum Instrumentation and Control

A Granville-Phillips digital gauge control unit with process control module, supporting two Convector (Pirani) gauges and one Bayard-Alpert Ion gauge is included to monitor system pressure. The Bayard-Alpert gauge tube, and the Convector that measures chamber pressure are located on the ISO160 flanged chamber neck. The second Convector is located to measure pressure at the roughing/backing line.

A circuit receiving a signal from an ion gauge related setpoint can be used to toggle the program between run and hold to keep below a programmed vacuum cap during periods of high gas load (vacuum/heat ramp delay).

Linearized, analog output provided by the gauge control may be coupled to a recorder when a recorder is ordered.

## Power Control

Power is proportionally controlled through use of a digitally controlled SCR three phase power module. This unit is phase angle fired control, and includes three phase current limiting. In the event of a power outage at higher temperature, the load temperature would drop to a level where a hard application of heat might thermally shock damage the parts.

Impedance match of the heating elements to the incoming power is accomplished through the conservatively rated 40 KVA transformer driven by this power module. Several safety features are tied to a main contactor supplying power to the SCR. If any of the safety features are not satisfied there are hardware and software interlocks that open this power circuit to protect the furnace and load.

## Atmosphere Control

Our vacuum furnaces can be ordered with Combination Vacuum and Inert Reducing Atmosphere control. Through programming, either vacuum or atmosphere can be chosen to make this an ideal R & D or laboratory furnace. When this option is ordered, the furnace can run Nitrogen as the purge gas. The process gas can be Hydrogen, Hydrogen Argon or Hydrogen Nitrogen.

A Bubbler to humidify the process gas would come standard with this option. A burnoff column to ignite excess process gas is also standard.

As with our standard atmosphere furnaces, this combination furnace comes with all the safety interlocks required with Hydrogen operation.

## Safety Features

- Thermocouple break protection (Thermocouple burn-up) assures that heating power is removed from the furnace in the event of sensor failure.
- Overtemperature indication is read on a separate control module from the monitor thermocouple. This overtemp alarm causes the heating elements to shut down as a further backup.

Other numerous interlock functions protecting the operator and equipment include:

- Panel Interlock
- High Cabinet Temperature
- Low Coolant Flow
- Low Air Pressure Switch
- Low Gas Pressure Switches
- Vacuum Ramp Delay
- Heaters are interlocked with the vacuum gauge control so that heating will not occur if there is insufficient vacuum.
- Thermal overload protection for the Turbo Molecular Pump
- High Vacuum isolation valve to protect the Turbo Pump during vent and quick cooling of the hot zone.

## Documentation

Facilities information is supplied to assist in site preparation for installation. An operating manual is supplied with the equipment. Worksheets included in the manual provide a convenient form to depict the desired process for entry into the microprocessor controller. The worksheets also serve as a hard copy of the program. The unit is shipped with an example program stored in memory, depicted by the example worksheet.

Wiring and plumbing schematics along with a published spare parts list are also included in the manual. Vendor supplied manuals for the program controller, overtemp, SCR, recorder, dewpointer, and other small items are supplied in our documentation.

A program and operation section has a complete button-by-button push instruction for installation of a generic program. The relatively simple operation of the furnace is well described and documented in the manual.

Note: Facility voltage should be specified at time of order.

# B-16 HOT ZONE

## 12" DIA X 18"

REV.	DATE	DESCRIPTION

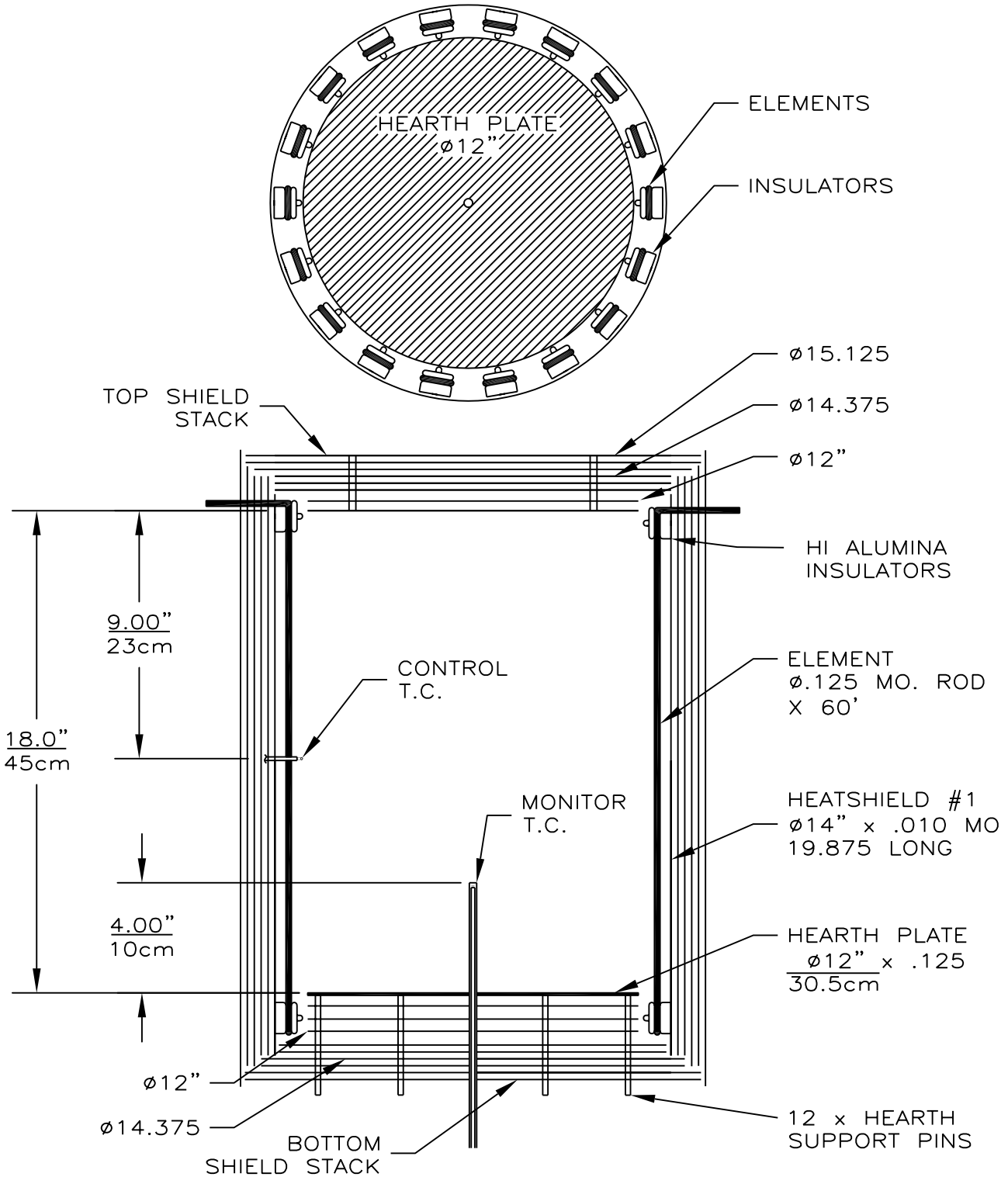

**NOTICE:** This document contains information which may be confidential and/or tradeseecret and/or proprietary to Concepts & Methods Co. Inc. and its' affiliates. This document is submitted to you in confidence and shall not be reproduced, disclosed to others, or used in manufacture without the express written permission of Concepts & Methods Co. Inc.

TOL'S EXCPT AS NOTED		DRN.BY: ZEVADA 11/12/01	 <b>Concepts &amp; Methods Company, Inc.</b>	
fract. ±1/32		APP.BY:		
.XX ±.010		DATE: 04/28/99	TITLE: B-16 HOT ZONE DIM.	
.XXX ±.005		MAT:	DWG.NO: 88202	
.XXXX ±.0005		FINISH:	SHEET 1 OF 1	
ANGLES ±1/2'			REV:	
B-16 FURNACE				
USED ON TASK	FWO			



*Manufacturers of High Temperature & High Vacuum Equipment*

370-G Industrial Road | San Carlos, CA 94070  
Phone (650) 593-1064 | Fax (650) 593-4458

B-Vac Hot Zone showing part survey thermocouple and stainless steel fixturing. Flag melt positioned at center for sight port verification.

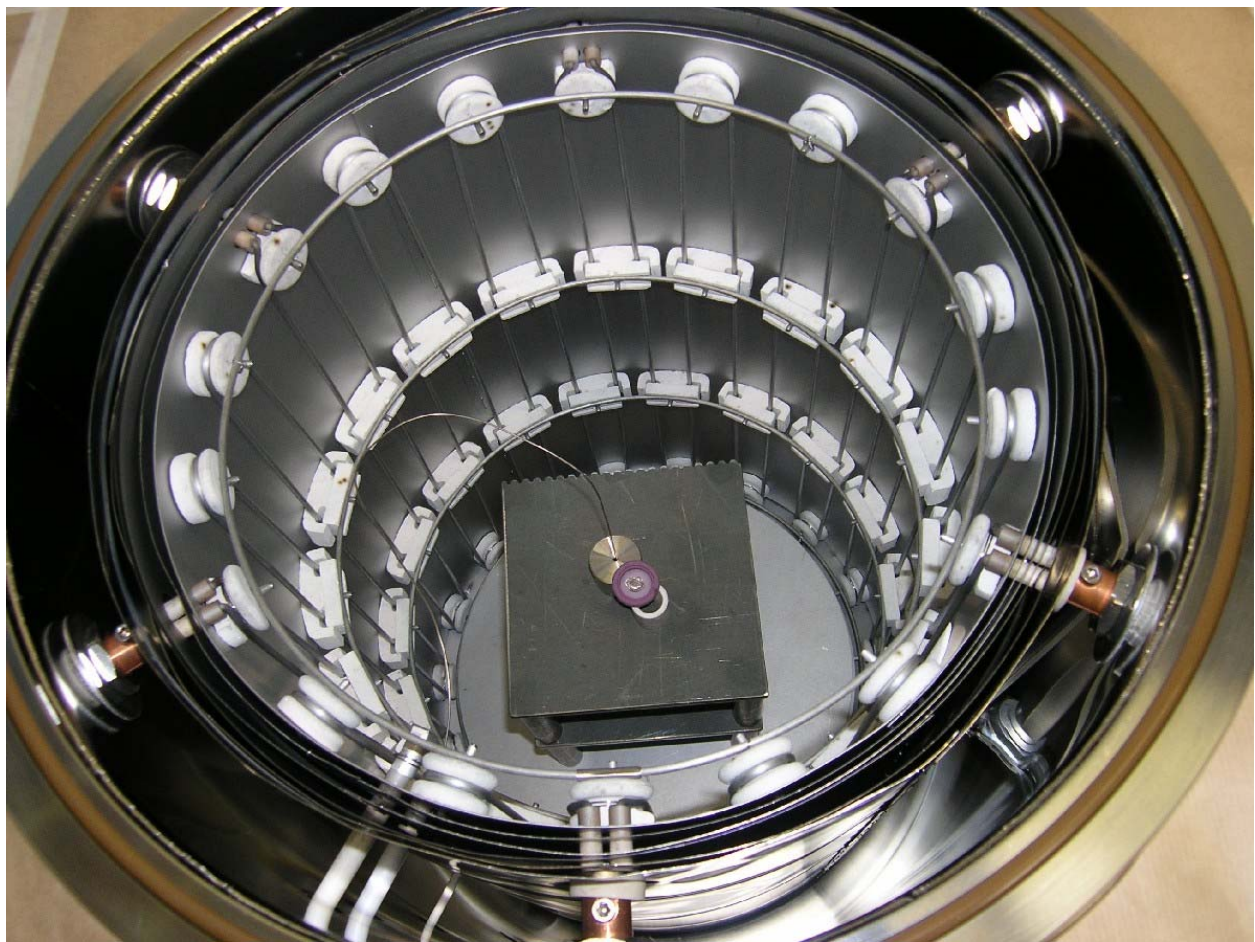

- A: 150 A/LEG 208V. 120@240V. OR 60@480V. 60Hz 3 PH DISCONNECT. 1/4" FPT
- B: NITROGEN, 25 TO 30 PSI (2BAR) AT A MAXIMUM FLOW OF 30 SCFH. 1/4" FPT
- C: COMP. AIR FOR VAC VALVES: 80-100 PSI (6-7 BAR) 1/2" FPT
- D: COOLING WATER SUPPLY; 25 PSI (2BAR) MIN AT A 4GPM (15 lpm) 1/2" FPT
- E: COOLING WATER RETURN OR PRESS. DRAIN IF USED. 1/2" FPT
- F: LINE PRESSURE REGULATORS SET AT 40 PSI (3 BAR)

**NOTE:** (MAX. BACK PRESSURE 15 PSIG AT 4 G.P.M.)  
 (1 BAR AT 15 lpm)

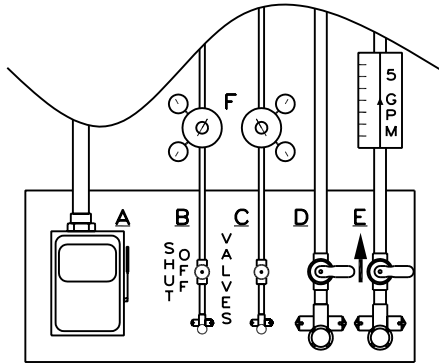

SUGGESTED UTILITY PANEL LAYOUT

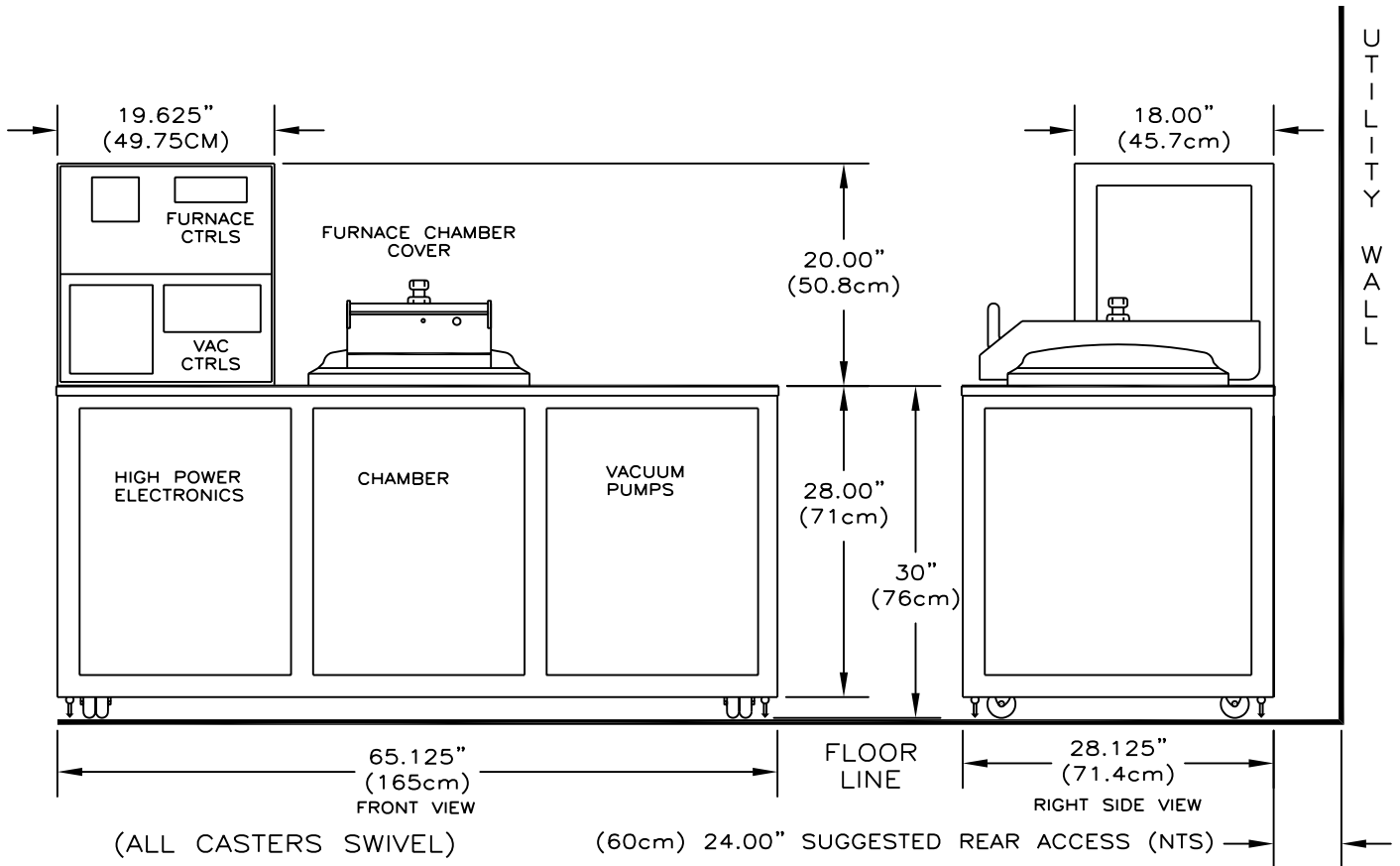

		TITLE: B-VAC FACILITY LAYOUT WITH DIM		
		DRN. BY: T BARULICH	APP. BY: TONY BARULICH	
USED ON TASK	FWO	DATE: 1-25-07	DWG. NO: 87698-2	SHEET 2 OF