

18" DIA. X 24" Work Area  
TURBO-PUMPED HIGH  
VACUUM FURNACE

For programmed continuous  
operation to 1250° C.



Size: 75" (185 cm) W. x 36" (90 cm) D. x 110" (270 cm)H.

*A High Vacuum and Atmosphere version of the CAMCo Model J Furnace.  
J-VAC Furnaces are available with ratings to 1600° C.*

### **Standard Features**

- 1000 LPM Turbo Pump
- High Vacuum isolation valve
- 19 Programs – 20 Segments per program
- Fully Automatic
- Vacuum Delay Setpoint
- All Stainless Steel construction
- 

### **Options**

Video Recorder  
Tower Indicating Lights – 3 color  
Survey Thermocouples  
Computer Controls  
Quick Cool Option  
Combination Hydrogen atmosphere



Manufacturers of High Temperature & High Vacuum Equipment

370-G Industrial Road | San Carlos, CA 94070  
 Phone (650) 593-1064 | Fax (650) 593-4458



## Specification Sheet

Equipment Model: JVAC-12-1824 High Vacuum Furnace

<b>Type</b>	Coldwall, Vertical Bell , Turbo Pumped
<b>Maximum Temperature</b>	1250 Degrees C.
<b>Hot Zone</b>	18" (45 cm) Dia. x 24" (60 cm) H. Nominal
<b>Frame Dimensions</b>	74" (137 cm) W. x 34" (86 cm) D. x 120" (305 cm) H.
<b>Power Requirements</b>	480V 3 Ph. 60A 60 Hz – 240V 3 Ph. 120A 60 Hz.
	380/400/415V 3 Ph. 60A 50 Hz.
<b>Gas Requirements</b>	25 – 50 psig, regulated, clean dry Nitrogen
<b>Turbo</b>	ISO 250, 1000L/PS, (38,000 rpm) Ceramic Bearings
<b>Thermocouple</b>	Type "K" Chromel Alumel/Control & Monitor Thermocouple
<b>Compressed Air</b>	80 PSI regulated Clean/Dry

Process vacuum at temperature 10-6 torr.

Vacuum at ambient, 10-7 torr.

**Cooling Requirements** - 35 psig, at 6 gallons per minute.

Note: Maximum backpressure is 15 psig.

Heat up ramp rate 75 degrees C per minute - empty chamber.

All molybdenum Hot Zone & elements. All insulators are made of High Alumina.

Element style - 1/8" molybdenum wire.

### Standard Features:

- 1000 L/PS Turbo Pump
- High Vacuum isolation gate valve
- Equipment on casters to roll into place
- Honeywell Controls - Ramp & Soak
- DCP302 Program Controller
- UDC2300 Overtemp Controller
- 19 Programs - 20 segments per program
- Sight glass for calibration melts
- Fully automatic - One button push starts the run. Automatically it pump down and cross over to high vacuum, ramp to temperature and soak – cool-down and post purge with nitrogen.

### Options:

- Computer Controls
- Video Recorder
- Tower Indicator Lights
- Survey Thermocouple-Type "K"
- Combination Hydrogen atm furnace

REV.	DATE	DESCRIPTION

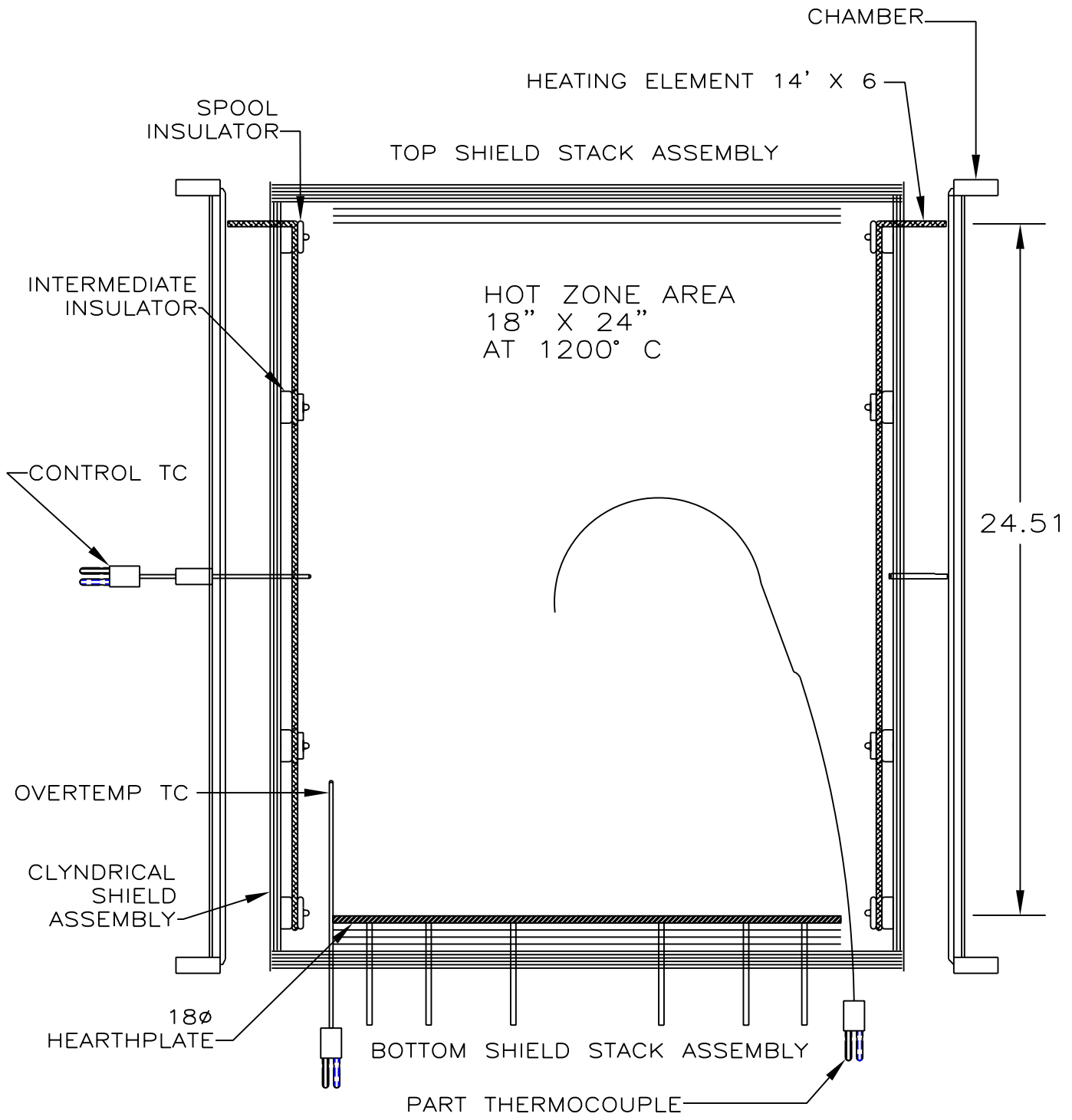

**NOTICE:** This document contains information which may be confidential and/or tradeseecret and/or proprietary to Concepts & Methods Co. Inc. and its' affiliates. This document is submitted to you in confidence and shall not be reproduced, disclosed to others, or used in manufacture without the express written permission of Concepts & Methods Co. Inc.

J-12 FURNACE USED ON TASK	FWO	TOL'S EXCPT AS NOTED	DRN.BY: T BARULICH			
		fract. ±1/32	APP.BY:			
		.XX ±.010	DATE: 3-26-05			
		.XXX ±.005	MAT: NOTED			
		.XXXX ±.0005	FINISH:	TITLE: J-12 HOTZONE DIM		
		ANGLES ±1/2'		DWG.NO: 88904	SHEET OF	REV:



Manufacturers of High Temperature & High Vacuum Equipment

370-G Industrial Road | San Carlos, CA 94070  
Phone (650) 593-1064 | Fax (650) 593-4458

## Equipment Description

### CAMCo 18”(45cm) Dia. x 24”(60cm) H., 1250 deg. C

#### **TURBO-PUMPED, HIGH VACUUM FURNACE**

*For Automatic, Programmed Operation to 1250 deg. C*

### Model JVAC-12-1824



## **Overview**

The model J Furnace currently has the largest hot zone at 1250° C available to our customers in the coldwall style chamber. Its hot zone is 18”(45cm) diameter by 24”(60cm) high. It has a bell type chamber assembly that is raised off the bottom chamber assembly to expose an 18”(45cm) diameter hearth plate that is located at a convenient height to load and unload parts of up to (60cm) 24 inches in height.

It is single zone controlled, using a modern Honeywell DCP302 microprocessor for programmed ramp and soak control of up to 19 programs of 19 segments each. It is designed to operate to operate at temperatures up to 1250 deg C (2000 F) at 10-6 torr vacuum. The furnace is fully automatic requiring the operator only to load the parts, select the desired program for processes, lower the chamber and press start. The furnace will automatically rough the chamber - cross over to high vacuum - ramp & soak to the pre-programmed temperature - cool down at a controlled rate and vent to atmosphere with nitrogen.

## **Base Unit**

The base unit measures 55”(140cm) wide by 34”(86cm) deep by 40”(100cm) high. Its' substantial frame is constructed of heavy wall square steel tubing. With the chamber fully raised the hoist and chamber assembly is 120 (305cm) inches high. Service access is readily gained through a hinged steel door and the removable front, side and rear panels.

The plate steel floor within the base unit supports the heating transformer and closes the bottom. Also contained within the base unit is the SCR unit, power components, and other electronics. At the lower right are the atmosphere control module, gas plumbing and cooling water plumbing. The high vacuum turbo pump, roughing pump and manifold are also located within the right side of the cabinet. In addition, the base frame supports the instrument console and the water-cooled chamber bottom end at a convenient operator height for loading of product. A fan at the rear of the base unit draws cooling air through a replaceable filter element to cool the power control unit and transformer.

A handy feature is the inclusion of **recessed heavy-duty casters**. The unit is easily rolled into place, and the leveling feet lowered to immobilize and level the equipment. **With the removal of the hoist assembly and the top cover this unit can fit through a standard door.** The finish used on this, and all CAMCo equipment is baked powder coating, chosen for its' durability. The stainless steel top skin reduces the possibility of load contamination.

## **Hoist Assembly**

The chamber/furnace assembly is mounted to the arm of the motor driven hoist assembly by which it may be raised to provide access to the work area. The mounting allows the chamber to lift with respect to the hoist. The hoist itself is screw driven, and cannot inadvertently lower on the removal of power. Its speed is approximately eighteen inches per minute, a rate that is slow enough to minimize jarring, while not being inconvenient. Limit switches control the extremes of travel. Large bearing areas assure hoist rigidity and long life, and further assist in providing close registration of the chamber to the chamber bottom assembly upon closing.

## Temperature Control

Temperature control and monitoring functions to 1250 deg. C. are achieved using type “K” Chromel vs. Alumel thermocouples. The control thermocouple, in close proximity to the element zone, ensure long furnace life by controlling the element temperatures to safe values regardless of load thermal mass. Multi-stage programmed control is achieved through use of a two channel Honeywell process controller which compares the setpoints with the inputs from thermocouples located in close proximity to the heating elements, sending an appropriate drive signal to the SCR power controllers. Totally automatic time/temperature programmed control of up to nineteen different, 19 segment programs may be stored.

Load temperature monitoring is provided by a second thermocouple located within close proximity to the load. It drives a Honeywell UDC2300 process monitor, which provides digital readout of the load area. This thermocouple provides an overtemperature shutdown signal. The process monitor also provides a safe chamber access interlock and access signal for the operator.

A thermocouple feedthrough at the bottom of the chamber, and related holes in the shields, allow survey thermocouples to be inserted to monitor actual temperature of load. These thermocouples can be used in conjunction with the “Active Closed Loop Braze Control”.

## Active Closed Loop Braze Control

The Furnace comes standard with one type “K” Inconel sheathed survey thermocouple that can be attached to the workload. This thermocouple drives a second channel on the program controller that can be integrated with the process control. These thermocouples are rated for use up to 1250° C (2250° F).

## Operation

The work is loaded onto the 18”(45cm) diameter hearth plate and the chamber is lowered via the hoist switch. One of nineteen selectable, user programmed thermal profiles is chosen, and the “start” key pressed. A one-button push will start the run and automatically it will rough the chamber, cross over to the high vacuum pump, ramp to temperature and soak, cool-down and vent with nitrogen. Upon completion of the cooldown portion of the program, the chamber is opened and unloaded.

## Chamber/Furnace assembly

The stainless steel water-jacketed chamber bottom end is mounted on the base unit. It is sealed in operation to the chamber by a flange containing a viton “O” ring. The location of the seal is such that it is well cooled and optically baffled assuring long life. The chamber bottom includes work and survey thermocouple feed-throughs, gas admission and exhausts plumbing. It supports the Molybdenum hearth and bottom end stack of six shields via the lower support structure.

The furnace chamber is located within the jacketed stainless steel chamber. It incorporates a Molybdenum heating element consisting of six sections each supported by high alumina insulators. This surrounds the eighteen-inch diameter by twenty-four-inch high work area. A series of four Molybdenum cylindrical heat shields and the top and bottom stack of four shields surround the elements. This assembly is supported from the inner wall of the chamber.

In addition, the chamber includes the insulated water-cooled power feedthroughs, control thermocouple, sightport, and required cylindrical heat shield support structure. Perforated stainless steel guards surround the heater power feedthroughs and provide electrical protection to the operator. The chamber assembly is supported by the hoist arm, and is located by pilot guides to assure accurate registration to the chamber bottom assembly when the furnace is lowered. Pneumatic clamping assures a positive seal to the bottom chamber assembly.

## Power Control

Power is proportionally controlled through use of a digitally controlled SCR three phase power module. This unit is phase angle fired control, and includes three phase current limiting made necessary by the strongly positive resistivity coefficient of the heating element. In the event of a power outage at higher temperature, the load temperature would drop to a level where a hard application of heat might thermally shock damage the parts. In this event, an abort relay will trip, and the program will resume and time out under process atmosphere without the application of heat.

Impedance match of the heating elements to the incoming power is accomplished through a conservatively rated 40 KVA transformer driven by this power module.

## **Vacuum System**

This automatically controlled, turbo pumped version of the type J Furnace is designed for clean, oil-free elevated temperature in a high vacuum atmosphere. From a cold start, the clean furnace will evacuate to the  $10^{-6}$  Torr range in approximately 15 minutes, and is capable of maintaining six-scale vacuum at temperature. When pumped for a longer period, lower pressures are easily attained. The vacuum plumbing is designed to provide convenient component access, and to provide maximum practical conductance to the chamber. Mass spectrometer leak checks are performed on all high vacuum assemblies. An internal water-cooled plate is strategically located to baffle the turbo-pump and vacuum gauging during heating to ensure long pump life.

The high vacuum system is specifically designed to handle the large gas loads presented by vacuum furnaces. An ISO250 flanged, 1000 L/Sec. ceramic bearing turbo molecular pump, capable of  $10^{-9}$  scale ultimate vacuum, is used for the application. The turbo-pump is capable of very rapid 3 thru 7 scale pumping of air and water vapor typically evolved during the earlier out-gassing part of the firing cycle. For maximum pumping speed, it is close coupled to the chamber pumping neck through the high conductance high vacuum gate valve, as are the chamber vacuum gauges and inert gas let-up valve.

Chamber roughing is accomplished through the turbo pump by a quiet, direct drive mechanical pump. At acceptable foreline pressure, the turbo-pump is automatically powered up. For ultra clean operations, a dry scroll or diaphragm pump can be substituted for the mechanical pump. The foreline includes a baked molecular sieve back-streaming trap and electro-pneumatic foreline valve.

## **Vacuum Instrumentation and Control**

A Granville-Phillips digital gauge control unit with process control module, supporting two Convectron (Pirani) gauges and one Bayard-Alpert Ion gauge is included to monitor system pressure. A self-cleaning degas feature helps keep the Ion gauge calibrated and the process consistent.

The Bayard-Alpert Ion gauge tube, and the Convectron that measures chamber pressure are located on the ISO250 flanged chamber neck. The second Convectron is located to measure pressure at the roughing/backing line.

## **Vacuum Ramp Delay**

A circuit receiving a signal from an ion gauge related set-point can be used to toggle the program controller between run and hold to keep below a programmed vacuum cap during periods of high gas load (vacuum/heat ramp delay).

Linearized, analog output provided by the gauge control may be coupled to a recorder when a recorder is ordered.

## **Optional Atmosphere Control**

Our vacuum furnaces can be ordered with Combination Vacuum and Inert Reducing Atmosphere control. Through programming, either vacuum or atmosphere can be chosen to make this an ideal R & D or laboratory furnace. When this option is ordered, the furnace can run either Nitrogen or Argon as the purge gas. The process gas can be Hydrogen, Hydrogen/ Argon or Hydrogen/ Nitrogen.

A Bubbler to humidify the process gas comes standard with this option. A burn-off column to ignite excess process gas is also standard.

As with our standard atmosphere furnaces, this combination furnace has all the safety interlocks required with Hydrogen operation.

## Safety Features

- Thermocouple break protection (Thermocouple burn-up) assures that heating power is removed from the furnace in the event of sensor failure.
- Over-temperature indication is read on a separate control module from the monitor thermocouple. This over-temp alarm causes the heating elements to shut down.

Other numerous interlock functions protecting the operator and equipment include:

- Panel Interlock
- High Cabinet Temperature
- Low Coolant Flow
- Low Gas Pressure Switches
- Vacuum Ramp Delay
- Heaters are interlocked with the vacuum gauge control so that heating will not occur if there is insufficient vacuum.
- Thermal overload protection for the Turbo Molecular Pump
- High Vacuum isolation valve to protect the Turbo Pump during vent and quick cooling of the hot zone.

## Documentation

Facilities information is supplied to assist in site preparation for installation. An operating manual is supplied with the equipment. Worksheets included in the manual provide a convenient form to depict the desired process for entry into the microprocessor controller. The worksheets also serve as a hard copy of the program. The unit is shipped with an example program stored in memory, depicted by the example worksheet.

Wiring and plumbing schematics along with a published spare parts list are also included in the manual. Vendor supplied manuals for the program controller, overtemp, SCR, recorder, dewpointer, and other small items are supplied in our documentation. A program and operation section has a complete button-by-button push instruction for installation of a generic program. Relatively simple operation of the furnace is well described and documented in the manual.

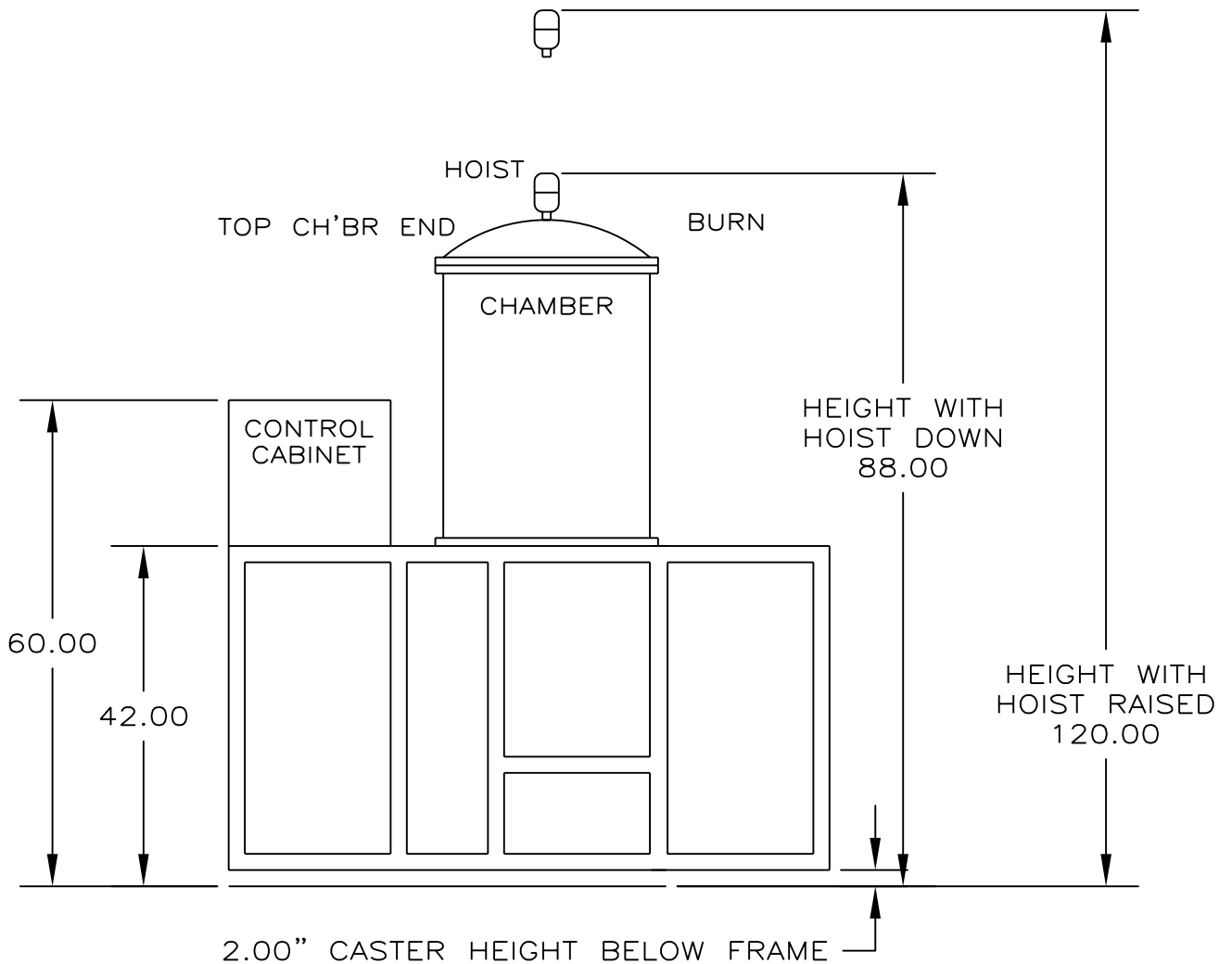
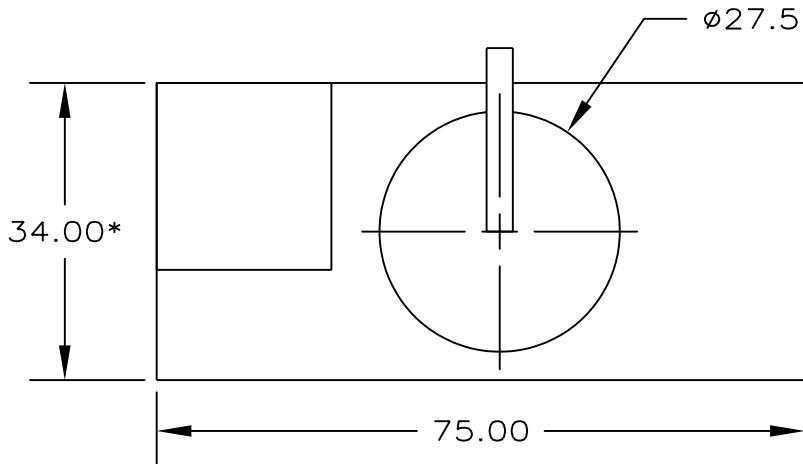

\*WITH HOIST REMOVED.

NOTE: WITH THE TOP END OF THE CHAMBER AND THE HOIST REMOVED, THE FURNACE WILL FIT THRU A 3-0 DOOR.

		TITLE: J FURNACE FACILITIES PREP.			 <b>Concepts &amp; Methods Company, Inc.</b>
		DRN.BY: ZEVADA	08/01/00	APP.BY: TONY BARULICH	
USED ON TASK	FWO	DATE:	DWG.NO: 88189	SHEET 3 OF 3	

**UTILITIES: PREPARED AS SHOWN BY CUSTOMER.**

- A: 120A./LEG @ 480V. 60Hz 3 PH DISCONNECT.
- B: NITROGEN, 25 TO 50 PSIG AT A MAXIMUM FLOW OF 50 SCFH
- C: HYDROGEN 25 TO 50 PSIG AT A MAXIMUM FLOW OF 30 SCFH
- D: PROCESS ATMOSPHERE EXHAUST (NOT NEEDED WITH BURNOFF OPTION)
- E: D.I. WATER FOR BUBBLER MAKEUP
- F: COOLING WATER SUPPLY; 30 PSIG MIN. AT 10 GPM.
- G: COOLING WATER RETURN OR PRESS. DRAIN IF USED.
- H: LINE PRESSURE REGULATORS SET AT 40 PSI.

- 1/4" SWAGELOK
- 1/4" SWAGELOK
- 3/8" TUBE
- 1/4" POLYFLOW
- 3/4" FPT
- 3/4" FPT

**NOTE: (MAX. BACK PRESSURE 15 PSIG AT 4 G.P.M.)**

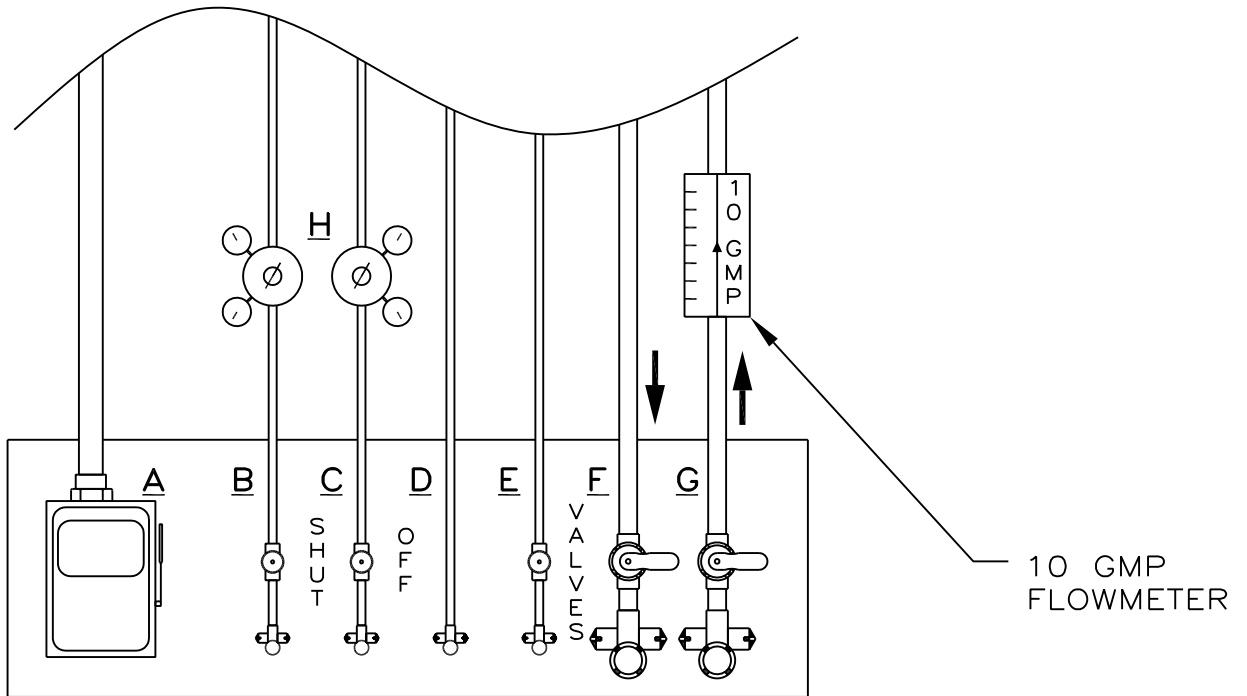

SUGGESTED UTILITY PANEL LAYOUT

		TITLE: J FURNACE FACILITIES PREP.		
		DRN.BY: ZEVADA 08/01/00	APP.BY: TONY BARULICH	
USED ON TASK	FWO	DATE:	DWG.NO: 88189	SHEET 1 OF 3

