



PHONE (650) 593-1064  
FAX (650) 593-4458

CONCEPTS & METHODS CO. INC.  
370-G INDUSTRIAL ROAD • SAN CARLOS, CA 94070

## Model J-16-1830

18" DIA. X 30" H. Work Area  
VERTICAL COLDWALL ATMOSPHERE FURNACE

For programmed continuous operation  
to 1600° C.

*Higher temperature and high vacuum versions available.*



Size: 54" (137 cm) W. x 34" (86 cm) D. x 121" (310 cm) H.

*The Model J Furnace available in ratings from 1200° C – 1600° C.*

### **Standard Features**

- Burnoff Column
- Bubbler for humidification of process gas
- 19 Programs – 20 Segments per program
- Fully Automatic

### **Options**

Video Recorder  
Dewpoint Monitor  
Survey Thermocouples  
Computer Controls



## Specification Sheet

Equipment Model: J-16-1830 Furnace

<b>Type</b>	Coldwall, Vertical Bell with lifting hoist
<b>Maximum Temperature</b>	1600 Degrees C.
<b>Hot Zone</b>	18" (45 cm) Dia. x 30" (75 cm) H. Nominal
<b>Frame Dimensions</b>	54" (137 cm) W. x 34" (86 cm) D. x 121" (310 cm) H.
<b>Power Requirements</b>	480V 3 Ph. 120A 60 Hz – 240V 3 Ph. 240A 60 Hz.
	380/400/415V 3 Ph. 120A 50 Hz.
<b>Gas Requirements</b>	25 – 50 psig, Nitrogen
	25 – 50 psig, Hydrogen
<b>Thermocouple</b>	Type "C" W5VSW26RE/Control & Monitor Thermocouple

Dual zone heat zone.

Purge gas is Nitrogen.

Process gas is Nitrogen or Hydrogen or a mixture of both.

Process gas can be humidified via a heated bubbler to over 18 degrees C. Dewpoint.

**Cooling Requirements** - 40 psig, at 10 gallons per min.

Note: maximum back pressure is 15 psig.

Heat up ramp rate 50 degrees C per minute - empty chamber.

All molybdenum Hot Zone & elements. All insulators are made of High Alumina.

Element style - 1/8" molybdenum wire.

### Standard Features:

- Burnoff column
- Bubbler for humidification of process gas
- Equipment on casters to roll into place
- Honeywell Controls - Ramp & Soak
- DCP302 Program Controller
- UDC2300 Overtemp Controller
- 19 Programs - 20 segments per program
- Vacuum Purge
- Dual Sight glass for calibration melts
- Fully automatic - One button push starts the run. Automatically it will purge - process gas fill - ramp to temperature and soak - bubbler for humidification of process gas - cooldown - post purge.

### Options:

- Chart Recorder
- Video Recorder
- Dewpoint Monitor
- Tower Indicator Lights
- Survey Thermocouple-Type "K"



## Equipment Description

### CAMCo 18" Dia. x 30" H., 1600 deg. C

#### **VERTICAL, DUAL ZONE, COLDWALL REDUCING/INERT ATMOSPHERE FURNACE**

For Programmed Continuous Operation to 1600 Deg. C.

### Model J-16-1830

#### **Overview**

The model J Furnace currently has the largest hot zone available to our customers in the coldwall style chamber. Its hot zone is 18" diameter by 30" high. It has a bell type chamber assembly that is raised off the bottom chamber assembly to expose an 18" diameter hearth plate that is located at a convenient height to load and unload parts of up to 24 inches in height.

It is dual zone controlled for temperature uniformity, using a modern Honeywell DCP302 microprocessor for programmed ramp and soak control of up to 19 programs of 19 segments each. It is designed to operate in a Hydrogen/Nitrogen mixed atmosphere and has the ability to divert a portion or all the process gas through a water filled bubbler to humidify the gas for processes requiring a reducing atmosphere. The furnace is fully automatic requiring the operator only to load the parts, select the desired program for processes, lower the chamber and press start. The furnace will automatically purge - process gas fill - ramp & soak to the pre-programmed temperature - cool down at a controlled rate and post purge.

#### **Base Unit**

The base unit measures 54" wide by 34" deep by 60" high. Its' substantial frame is constructed of heavy wall square steel tubing. With the chamber fully raised the hoist and chamber assembly is 121 inches high. Service access is readily gained through a hinged steel door and the removable front, side and rear panels.

The plate steel floor within the base unit supports the heating transformers and closes the bottom. Also contained within the base unit are the SCR units, power components, and other electronics. At the lower right are the atmosphere control module, gas plumbing and cooling water plumbing. The vacuum purge pump and manifold are also located within the right side of the cabinet. In addition, the base frame supports the instrument console and the water-cooled chamber bottom end at a convenient operator height for loading of product. A fan at the rear of the base unit draws cooling air through a replaceable filter element to cool the power control units and transformers. A handy feature is the inclusion of recessed heavy-duty casters. The unit is easily rolled into place, and the leveling feet lowered to immobilize and level the equipment. **With the removal of the hoist assembly and the top cover this unit can fit through a standard door.** The finish used on this, and all CAMCo equipment is baked powder coating, chosen for its' durability. The stainless steel top skin reduces the possibility of load contamination.

#### **Hoist Assembly**

The chamber/furnace assembly is mounted to the arm of the motor driven hoist assembly by which it may be raised to provide access to the work area. The mounting allows the chamber to lift with respect to the hoist. The hoist itself is screw driven, and cannot inadvertently lower on the removal of power. Its speed is approximately eighteen inches per minute, a rate that is slow enough to minimize jarring, while not being inconvenient. Limit switches control the extremes of travel. Large bearing areas assure hoist rigidity and long life, and further assist in providing close registration of the chamber to the chamber bottom assembly upon closing.

## Temperature Control

Temperature control and monitoring functions to 1600 deg. C. are achieved using type “C” Tungsten 5% vs. 26% Rhenium thermocouples. Two of these, in close proximity to the two element zones, ensure long furnace life by controlling the element temperatures to safe values regardless of load thermal mass. Multi-stage programmed control is achieved through use of a two channel Honeywell process controller which compares the setpoints with the inputs from thermocouples located in close proximity to the heating elements, sending appropriate drive signals to the SCR power controllers. Totally automatic time/temperature programmed control of up to nineteen different, 19 segment programs may be stored.

Load temperature monitoring is provided by a second thermocouple located within close proximity to the load. It drives a Honeywell UDC2500 process monitor, which provides digital readout of the load area temperature and provides an overtemperature shutdown signal. The process monitor also provides a safe chamber access interlock and access signal for the operator.

A thermocouple feedthrough at the side of the chamber and related holes in the cylindrical shields allow survey thermocouples to be inserted to monitor actual temperature of load. These thermocouples can be used in conjunction with the “Active Closed Loop Braze Control”.

## Active Closed Loop Braze Control

The Furnace comes standard with one type “K” Inconel sheathed survey thermocouple that can be attached to the workload. This thermocouple drives a second channel on the program controller that can be integrated with the process control. These thermocouples are rated for use up to 1200° C (2200° F).

## Operation

The work is loaded onto the 18” diameter hearth plate and the chamber is lowered via the hoist switch. One of nineteen selectable, user programmed thermal profiles is chosen, and the “start” key pressed. A one button push will start the run and automatically it will purge, process gas fill, ramp to temperature and soak, activate the bubbler for humidification of process gas, cooldown and post purge. Upon completion of the cooldown portion of the program, the chamber is opened and unloaded.

## Chamber/Furnace assembly

The water-jacketed chamber bottom end is mounted on the base unit. It is sealed in operation to the chamber by a flange containing a silicone “O” ring. The location of the seal is such that it is well cooled and optically baffled assuring long life. The chamber bottom includes work and survey thermocouple feedthroughs and gas admission and exhaust plumbing. It supports the Molybdenum hearth and bottom end stack of eight shields via the lower support structure.

The furnace chamber is located within the jacketed stainless steel chamber. It incorporates two Molybdenum heating element zones of six sections each supported by high alumina insulators. These surround the eighteen-inch diameter by twenty-four high work area. A series of six Molybdenum cylindrical heat shields and the top and bottom stack of eight shields surround the elements. This assembly is supported from the inner wall of the chamber.

In addition, the chamber includes the insulated water-cooled power feedthroughs, control thermocouples, two sightports, and required cylindrical heat shield support structure. Perforated stainless steel guards surround the heater power feedthroughs and provide electrical protection to the operator. The chamber assembly is supported by the hoist arm, and is located by pilot guides to assure accurate registration to the chamber bottom assembly when the furnace is lowered. Pneumatic clamping assures a positive seal to the bottom chamber assembly.

## Power Control

Power is proportionally controlled through use of two digitally controlled SCR three phase power modules. These units are phase angle fired control, and include three phase current limiting made necessary by the strongly positive resistivity coefficient of the heating element. In the event of a power outage at higher temperature, the load temperature would drop to a level where a hard application of heat might thermally shock damage the parts. In this event, an abort relay will trip, and the program will resume and time out under process atmosphere without the application of heat.

Impedance match of the heating elements to the incoming power is accomplished through two conservatively rated 40 KVA transformers driven by this power module.

## Atmosphere Control

Customer supplied Hydrogen and Nitrogen gasses are admitted to the chamber through programmed valves and preset flowmeters. An interlock is included, which provides for automatic Nitrogen purge in the event of loss of Hydrogen or chamber pressure.

Operator set flowmeters control the flow of gasses to achieve the appropriate operating atmosphere.

Included is a system which, when called to do so by the installed program, humidifies a portion of the selected process gas via a bubbler column. This gas is then recombined with the remaining process gas in a pre-selected ratio to obtain the desired process dewpoint.

The included bubbler column will humidify the process gas to a dewpoint of up to 20 degrees C. Higher dewpoint equipment, and controlled temperature bubblers are available.

Exhaust gas is routed through a check valve and out a fitting at the rear of the cabinet. This valve establishes a slight positive pressure when the chamber is closed and sealed. As a safety feature, absence of this pressure prevents admission of hydrogen and inhibits the application of heater power. An exhaust gas burnoff column electronically ignites the waste gas. Ignition is called for automatically at all times that Hydrogen is called for, and the unit attempts re-ignition should the flame be inadvertently extinguished. The ignitor is automatically tested to assure proper operation each time a run is started.

All gas plumbing and components are **stainless steel**. All gas connections are high-quality, high-pressure swagelok fittings.

## Standard Safety Features

Thermocouple break protection assures that heating power is removed from the furnace in the event of sensor failure. Overtemperature indication is read on a separate control module from the monitor thermocouple. This overtemp alarm causes the heating elements to shut down as a further backup.

Other numerous interlock functions protecting the operator and equipment include:

- Panel Interlock
- High Cabinet Temperature
- Low Coolant Flow
- Low Gas Pressure Switches
- Hydrogen is prohibited from entering the system and heating cannot begin until the chamber cover is closed, sealed and purged. At the end of a programmed run the chamber is inhibited from being opened until the work has cooled to a predefined safe temperature.
- The model J Furnace comes standard with a vacuum purge feature that evacuates the chamber of all air. The chamber is then normally programmed to let up to an atmosphere of Nitrogen before Hydrogen can be admitted.
- A Purge Assure Circuit provides an internally set minimum timed Nitrogen purge regardless of the program status whenever power or the program is interrupted.

## Documentation

Facilities information is supplied to assist in site preparation for installation. An operating manual is supplied with the equipment. Worksheets included in the manual provide a convenient form to depict the desired process for entry into the microprocessor controller. The worksheets also serve as a hard copy of the program. The unit is shipped with an example program stored in memory, depicted by the example worksheet.

Wiring and plumbing schematics along with a published spare parts list are also included in the manual. Vendor supplied manuals for the program controller, overtemp, SCR, recorder, dewpointer, and other small items are supplied in our documentation. A program and operation section has a complete button-by-button push instruction for installation of a generic program. The relatively simple operation of the furnace is well described and documented in the manual.

REV.	DATE	DESCRIPTION

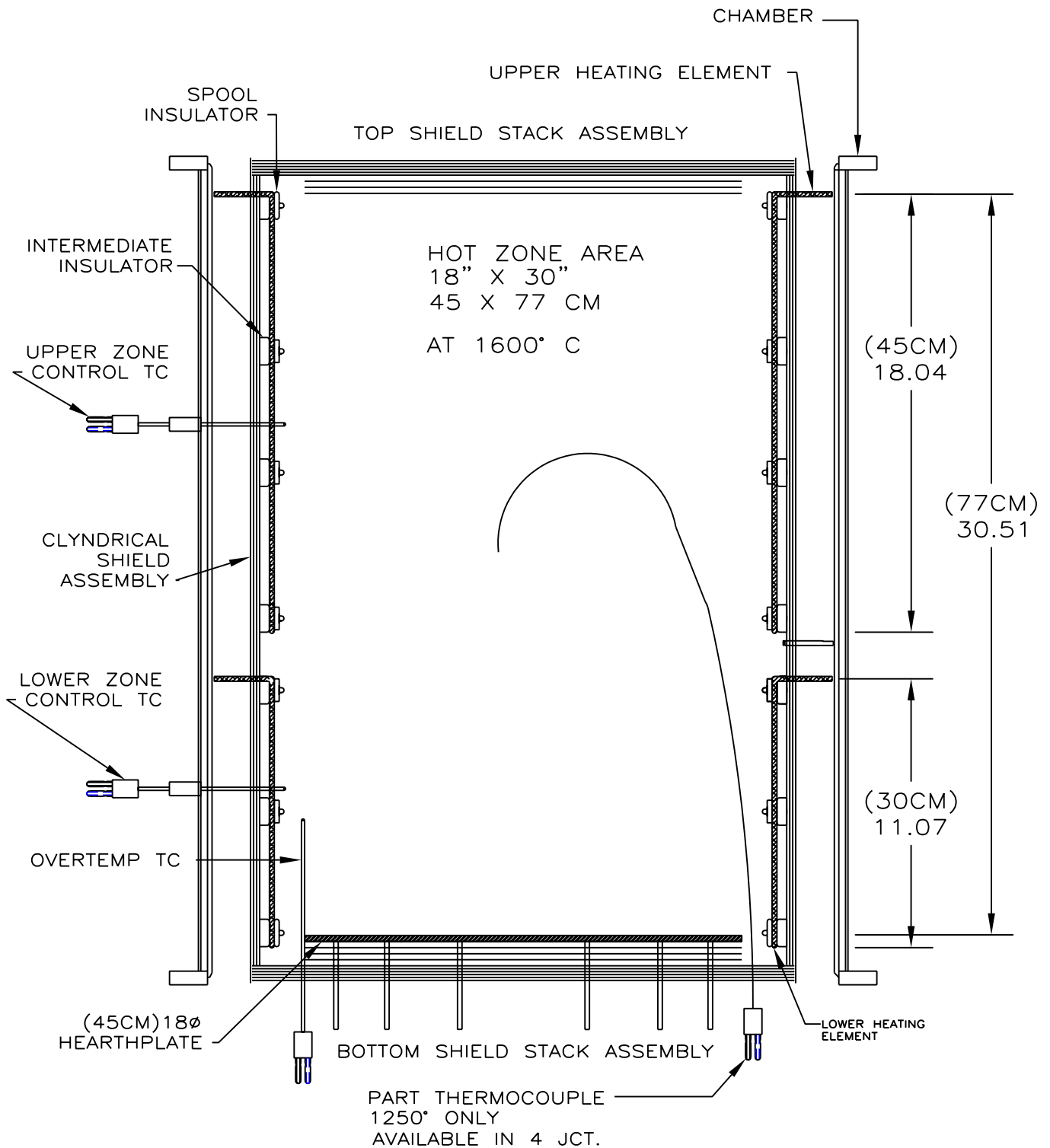

**NOTICE:** This document contains information which may be confidential and/or tradeseecret and/or proprietary to Concepts & Methods Co. Inc. and its' affiliates. This document is submitted to you in confidence and shall not be reproduced, disclosed to others, or used in manufacture without the express written permission of Concepts & Methods Co. Inc.

		TOL'S EXCPT AS NOTED	DRN.BY: T BARULICH	<b>CAMG</b> Concepts & Methods Company, Inc.
		fract. ±1/32	APP.BY:	
		.XX ±.010	DATE: 4-20-05	TITLE: J-16 HOTZONE DIM
J-16 FURNACE		.XXX ±.005	MAT: NOTED	DWG.NO: 88912
USED ON TASK	FWO	.XXXX ±.0005	FINISH:	SHEET OF
		ANGLES ±1/2'		REV:

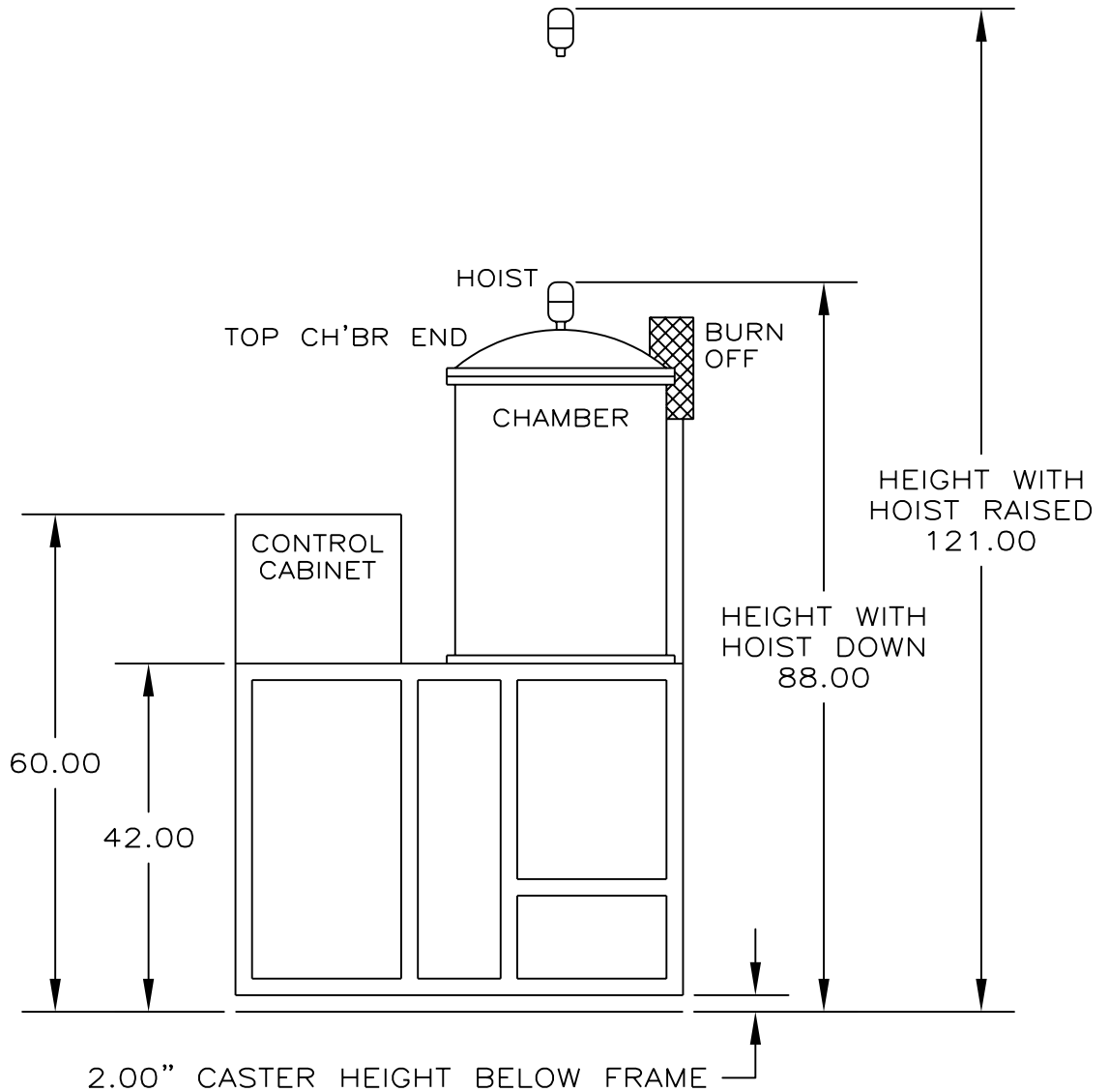
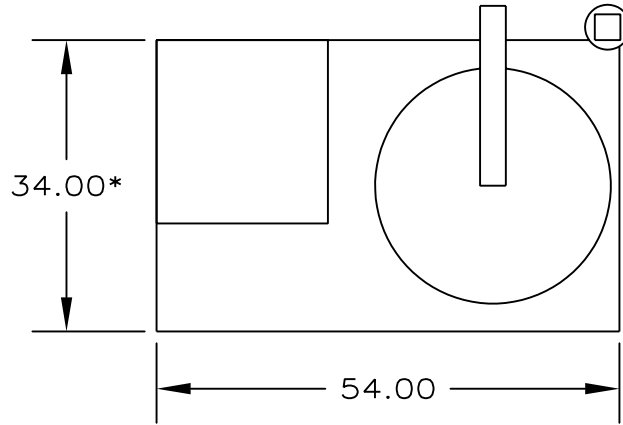

\*WITH HOIST REMOVED.

NOTE: WITH THE TOP END OF THE CHAMBER AND THE HOIST REMOVED, THE FURNACE WILL FIT THRU A 3-O DOOR.

		TITLE: J FURNACE FACILITIES PREP.			
		DRN.BY: ZEVADA	08/01/00	APP.BY: TONY BARULICH	
USED ON TASK	FWO	DATE:	DWG.NO: 88189	SHEET 3 OF 3	

REV.	DATE	DESCRIPTION

UTILITIES: PREPARED AS SHOWN BY CUSTOMER.

- |  |               |
|--|---------------|
| A: 120A./LEG @ 480V. 60Hz 3 PH DISCONNECT.                     |               |
| B: NITROGEN, 25 TO 50 PSIG AT A MAXIMUM FLOW OF 50 SCFH        | 1/4" SWAGELOK |
| C: HYDROGEN 25 TO 50 PSIG AT A MAXIMUM FLOW OF 30 SCFH         | 1/4" SWAGELOK |
| D: CLEAN DRY AIR, REGULATED AT 90 PSI                          | 1/4" SWAGELOK |
| E: PROCESS ATMOSPHERE EXHAUST (NOT NEEDED WITH BURNOFF OPTION) | 3/8" TUBE     |
| F: D.I. WATER FOR BUBBLER MAKEUP                               | 1/4" POLYFLOW |
| H: COOLING WATER SUPPLY; 30 PSIG MIN. AT 10 GPM.               | 3/4" FPT      |
| I: COOLING WATER RETURN OR PRESS. DRAIN IF USED.               | 3/4" FPT      |
| J: LINE PRESSURE REGULATORS SET AT 40 PSI.                     |               |

NOTE: (MAX. BACK PRESSURE 15 PSIG AT 4 G.P.M.)

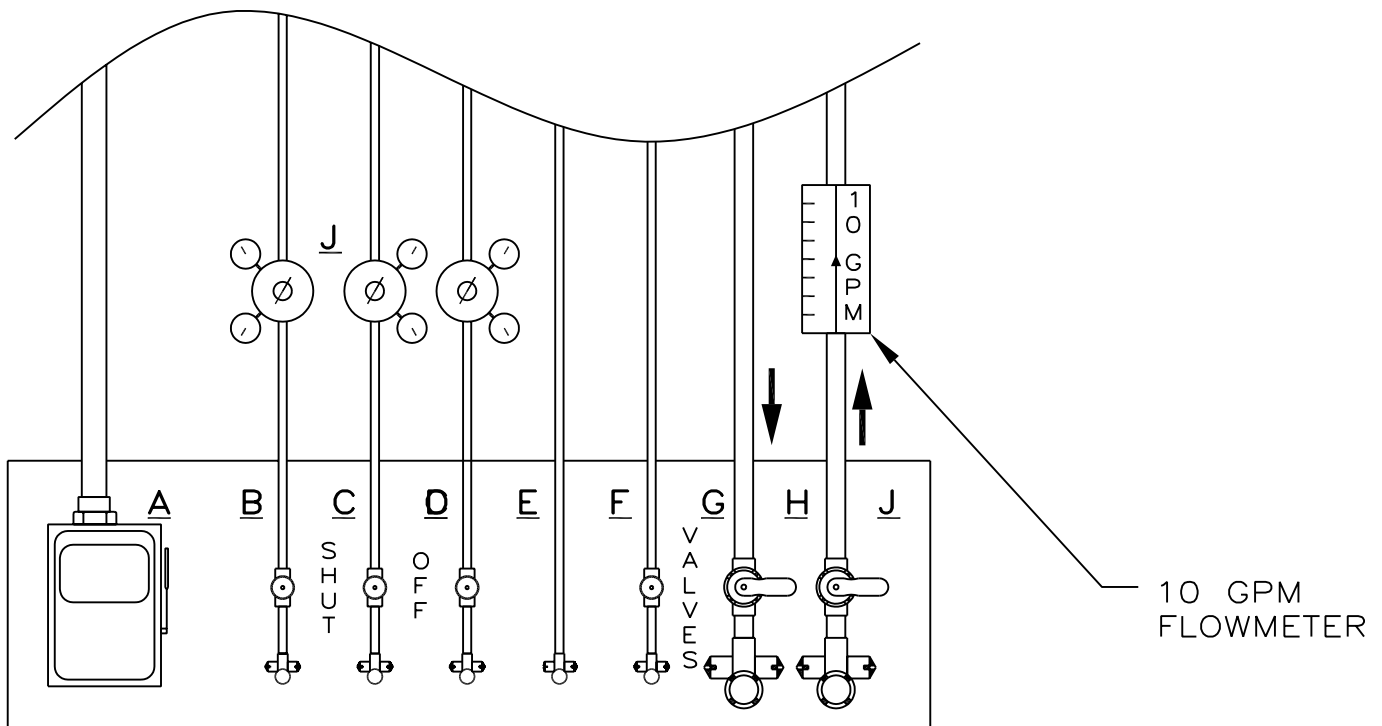

SUGGESTED UTILITY PANEL LAYOUT

NOTE; WATER SUPPLY SHOULD BE CONNECTED TO EMERGENCY CITY WATER BACK UP IN CASE OF POWER FAILURE AT HIGHR TEMPERATURE OPERATION

**NOTICE:** This document contains information which may be confidential and/or tradeseecret and/or proprietary to Concepts & Methods Co. Inc. and its' affiliates. This document is submitted to you in confidence and shall not be reproduced, disclosed to others, or used in manufacture without the express written permission of Concepts & Methods Co. Inc.

		TOL'S EXCPT AS NOTED	DRN.BY: T BARULICH	<b>CAMG</b> Concepts & Methods Company, Inc.
		fract. ±1/32	APP.BY:	
		.XX ±.010	DATE: 7-20-05	TITLE: J FURNACE FACILITIES PREP.
J-VAC COMBO 18X48	318	.XXX ±.005	MAT: NOTED	DWG.NO:
USED ON TASK	FWO	.XXXX ±.0005	FINISH:	SHEET 1 OF 3
		ANGLES ±1/2"		REV: